

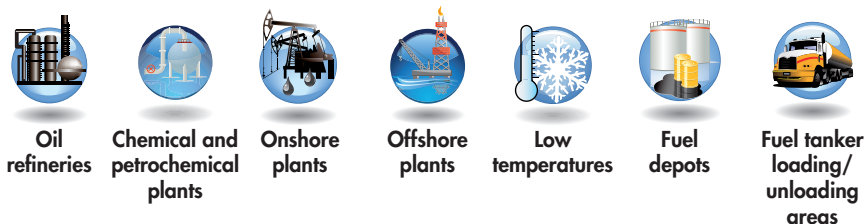

EWA series of lighting fixtures for discharge lamps has been designed in compliance with ATEX Directive 2014/34/UE for all those areas defined as “hazardous” due to the presence of potentially explosive flammable gases and dusts where good local lighting is a necessity. The body of the lamp is made of low copper content aluminium alloy, the globe is made of borosilicate glass and has excellent thermal and mechanical properties. For this reason, the fixture can also be installed without a protective guard. The resistance of this lighting fixture to high (+60°C) and low (-50°C) temperatures makes it ideal for use in any type of climatic condition and it can be used in plants worldwide.

As EWA series was designed with the “Ex d” protection method the “entry” to the fixture, as specified in the installation standard (EN/IEC 60079-14), must be only through an Ex “barrier” cable gland (sealed) or, in the case of a conduit system, with an EYS, EZS sealing fittings.

Application sectors



CERTIFICATION DATA

Classification:	Group II	Category 2GD		
Installation:	zone 1 - zone 2 (Gas)	zone 21 - zone 22 (Dust)		
Marking:	CE 0722 (Ex) II 2GD Ex d IIC T.. Gb - Ex tb IIIC T..°C Db IP66			
Certification:	ATEX	CESI 12 ATEX 006		
	IEC Ex	CES 07.0004	All IEC Ex and TR CU certification contact comm@antideflagrante.com	
	TR CU	AVAILABLE		
Standards:	CENELEC EN 60079-0: 2012, EN 60079-1: 2007, EN 60079-7: 2007, EN 60079-31: 2009 and EUROPEAN DIRECTIVE 2014/34/UE IEC 60079-0: 2012, IEC 60079-1: 2007, IEC 60079-7: 2007, IEC 60079-31: 2009 European Directive 2006/95 Low voltage European Directive 2004/108 Electromagnetic compatibility European Directive 2003/108 WEEE Waste electrical and electronic equipment European Directive 2011/64 RoHS			
Class temperature:	See the selection table			
Ambient temperature:	Standard -20°C +60°C	Special -50°C +60°C not possible for model EWA...100		
Degree of protection:	IP66			



MECHANICAL FEATURES

Body:	Low copper content aluminium alloy Complete with housing for electrical components
Globe:	Shock and high temperature resistant borosilicate glass with aluminium shade ring
Gaskets:	Silicone acid/hydrocarbon resistant
Guard:	Electro-polished stainless steel. Can also be supplied on request without a guard as the lighting fixture has passed the glass breakage test (4 Joule EN60079-0 / IEC60079-0)
Mounting:	See "EWA series dimensional drawings"
Bolts and screws:	Stainless steel
Entries:	3/4" NPT threads
Coating:	Polyester coating Ral 7035 (Light grey)
Corrosion Resistance:	The STANDARD of the aluminium alloy used by manufacturer has passed the tests required by standards EN60068-2-30 (hot/humid cycles) and EN60068-2-11 (salt mist tests)

ELECTRICAL FEATURES

Lamp holder:	E27 or E40 ceramic
Ballast:	Electromechanical
Rated voltage:	230 V AC
Rated frequency:	50 Hz
Connection:	Direct connection to the terminal box L, N, Pe. Section 4mm ²
Power factor:	0.96
Wiring:	Silicone rubber cables with glass braid insulation for high temperatures

ACCESSORIES AVAILABLE / SPECIAL REQUESTS

Discharge lamp
 Different rated voltages
 Rated frequency: 60 Hz at 230 V (code EWA-5080F5/60)
 External reflector
 Cable gland: for armoured cable or for non-armoured cable GAS UNI ISO 7/1 thread **both sealed execution**
 Bracket for pole mounting



Code	Dimensions mm			Lamp type	Lamp holder	Watt	Class Ta=+60°C	Max Temp. superf. °C	Weight kg	mm
	A	B	C							
EWAT-5080N2	610	220	235	Sodium vapour	E 40	100	T4	132	10,4	240x240x660
EWAT-5080N4	610	220	235	Sodium vapour	E 40	150	T4	132	11,4	240x240x660
EWAT-5080N5	610	220	235	Sodium vapour	E 40	250	T3	159	12,4	240x240x660
EWAT-50100N6	677	280	265	Sodium vapour	E 40	400	T3	164	17,1	280x280x850
EWAT-5080IM2	610	220	235	Metal halide	E 27	100	T4	130	10,3	240x240x660
EWAT-5080IM4	610	220	235	Metal halide	E 27	150	T4	130	11,1	240x240x660
EWAT-5080IM5	610	220	235	Metal halide	E 40	250	T3	180	12,7	240x240x660
EWAT-50100IM6	677	280	265	Metal halide	E 40	400	T3	163	15,5	280x280x850

EWAGC-5080N2	643	220	235	Sodium vapour	E 40	100	T4	132	10,4	240x240x660
EWAGC-5080N4	643	220	235	Sodium vapour	E 40	150	T4	132	11,2	240x240x660
EWAGC-5080N5	643	220	235	Sodium vapour	E 40	250	T3	159	12,5	240x240x660
EWAGC-50100N6	713	280	265	Sodium vapour	E 40	400	T3	164	17,9	280x280x850
EWAGC-5080IM2	643	220	235	Metal halide	E 27	100	T4	130	10,1	240x240x660
EWAGC-5080IM4	643	220	235	Metal halide	E 27	150	T4	130	10,9	240x240x660
EWAGC-5080IM5	643	220	235	Metal halide	E 40	250	T3	180	12,4	240x240x660
EWAGC-50100IM6	713	280	265	Metal halide	E 40	400	T3	163	16,6	280x280x850

EWAT Pendant mounting

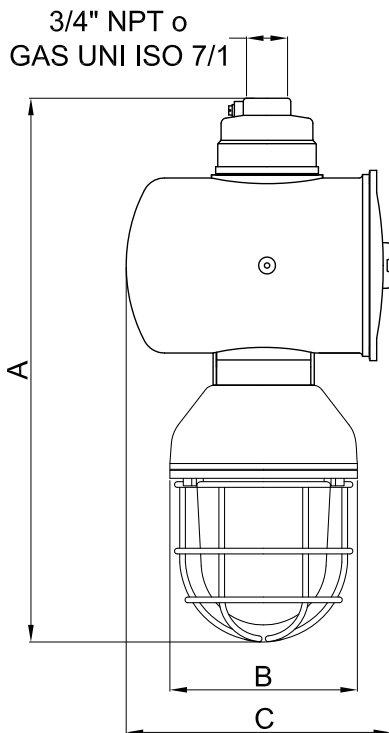

EWAGC Pendant mounting with eyebolt

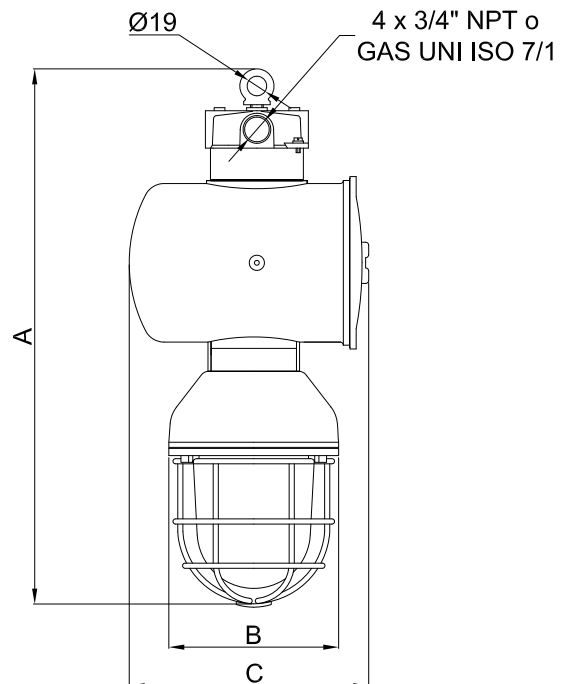



EWA series selection chart

Code	Dimensions mm			Lamp typo	Lamp holder	Watt	Class Ta=+60°C	Max Temp. superf. °C	Weight kg	mm
	A	B	C							
EWAIX-5080N2	592	500	235	Sodium vapour	E 40	100	T4	132	10,7	280x280x850
EWAIX-5080N4	592	500	235	Sodium vapour	E 40	150	T4	132	11,5	280x280x850
EWAIX-5080N5	592	500	235	Sodium vapour	E 40	250	T3	159	12,8	280x280x850
EWAIX-50100N6	650	547	265	Sodium vapour	E 40	400	T3	164	15,4	280x280x850
EWAIX-5080IM2	592	500	235	Metal halide	E 27	100	T4	130	10,4	280x280x850
EWAIX-5080IM4	592	500	235	Metal halide	E 27	150	T4	130	11,2	280x280x850
EWAIX-5080IM5	592	500	235	Metal halide	E 40	250	T3	180	12,7	280x280x850
EWAIX-50100IM6	650	547	265	Metal halide	E 40	400	T3	163	14,1	280x280x850

EWAX-5080N2	610	220	235	Sodium vapour	E 40	100	T4	132	10,6	240x240x660
EWAX-5080N4	610	220	235	Sodium vapour	E 40	150	T4	132	11,4	240x240x660
EWAX-5080N5	610	220	235	Sodium vapour	E 40	250	T3	159	12,7	240x240x660
EWAX-50100N6	677	280	265	Sodium vapour	E 40	400	T3	164	16,2	280x280x850
EWAX-5080IM2	610	220	235	Metal halide	E 27	100	T4	130	10,3	240x240x660
EWAX-5080IM4	610	220	235	Metal halide	E 27	150	T4	130	11,1	240x240x660
EWAX-5080IM5	610	220	235	Metal halide	E 40	250	T3	180	12,7	240x240x660
EWAX-50100IM6	677	280	265	Metal halide	E 40	400	T3	163	16,0	280x280x850

EWAIX Wall mounting with 30° bracket

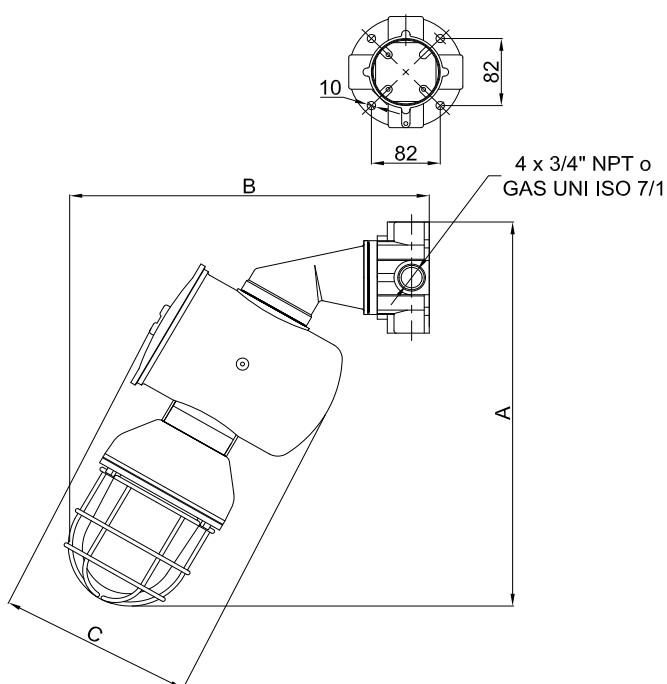

EWAX Ceiling mounting

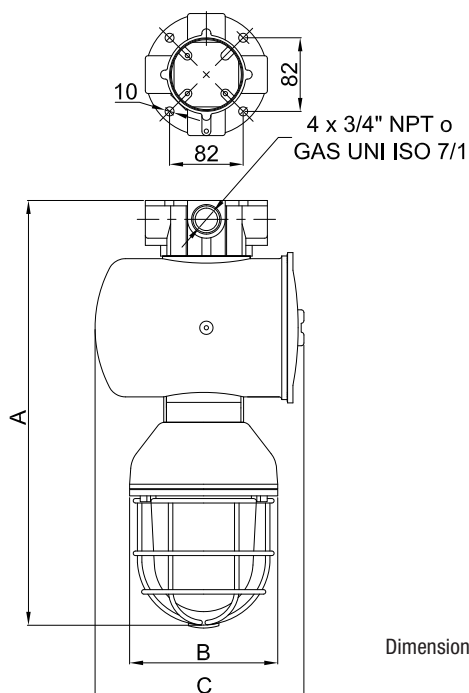

Dimensions in mm



ILLUSTRATION	DESCRIPTION	MODEL	FEATURES	CODE	KEY
	High pressure sodium vapour lamp	E40	100 W (SE100W)	LAMPNAV100WPLUS	
			150 W (SE150W)	LAMPNAV150WPLUS	
			250 W (SE250W)	LAMPNAV250WPLUS	
			400 W (SE400W)	LAMPNAV400WPLUS	
	Metal halide lamp	E27	100 W (ME100W)	LAMP100WJM	
			150 W (ME150W)	LAMP150WJM	
		E40	230 W (ME250W)	LAMP230WJM	
			360 W (ME400W)	LAMP360WJM	
	Cable gland		For models and codes, visit www.antideflagrante.com		
	Reflector	80	White painted aluminium Stainless steel	G80-427 G80-427IN	
		100	White painted aluminium Stainless steel	G100-427 G100-427IN	
	Dome reflector	80	White painted aluminium	G80-427D	
		100	White painted aluminium	G100-427D	
	30° inclined dome reflector	80	White painted aluminium	G80-427DI	
		100	Contact our Sales Office for availability		
	Galvanised steel brackets for pole mounting (see installation and mounting methods)	80	1 1/4" pole	G4-0541	
		100		G4-0542	
		80	1 1/2" pole	G5-0541	
		100		G5-0542	
		80	2" pole	G6-0541	
		100		G6-0542	
80	2 1/2" pole	G7-0541			
100		G7-0542			



EWA series Accessories and spare parts available on request

ILLUSTRATION	DESCRIPTION	MODEL	FEATURES	CODE	KEY
	O-ring	Globo 80	Material: silicone	K34-131S	
		Globo 100		K27-131S	
	Ballast for sodium vapour and metal halide lamps		100 W	R-100NA	
			150 W	R-150NA	
			250 W	R-250NA	
			400 W (sodium) 400 W (halide)	R-400NA R-400	
	Metal capacitor	5080N2	16µF 250V	F-16	
		5080N4	20µF 250V	F-20	
		5080N5	35µF 250V	F-35	
		50100N6	50µF 250V	F-50	
		5080IM2	12,5µF 250V	F-12,5	
		5080IM4	20µF 250V	F-20	
		5080IM5	30µF 250V	F-30	
		50100IM6	40µF 250V	F-40	
	Ceramic lamp holder	E27	250V 4A	PORT E-27	
		E40	750V 16A	PORT E-40	
	Igniter		50-400 W	R100	
	Globe with shade ring	80	Borosilicate glass globe	G80-0440CM	
		100	Threaded aluminium shade ring	G100-0440CM	
	Protective guard	80	Material: electro-polished stainless steel	G80-0417	
		100		G100-0417	



ILLUSTRATION	DESCRIPTION	MODEL	FEATURES	CODE	KEY
	Pendant eyebolt		In galvanised steel	G0F-8	
	Pendant mounting EWA		1 x 3/4" entry	G-0213	
	Pendant mounting with eyebolt EWAGC		4 x 3/4" entries	G-0216	
	Ceiling mounting EWAX		4 x 3/4" entries	G-0214	
	Wall mountings with bracket EWAIX		4 x 3/4" entries	G-0215	



Example of pole mounting

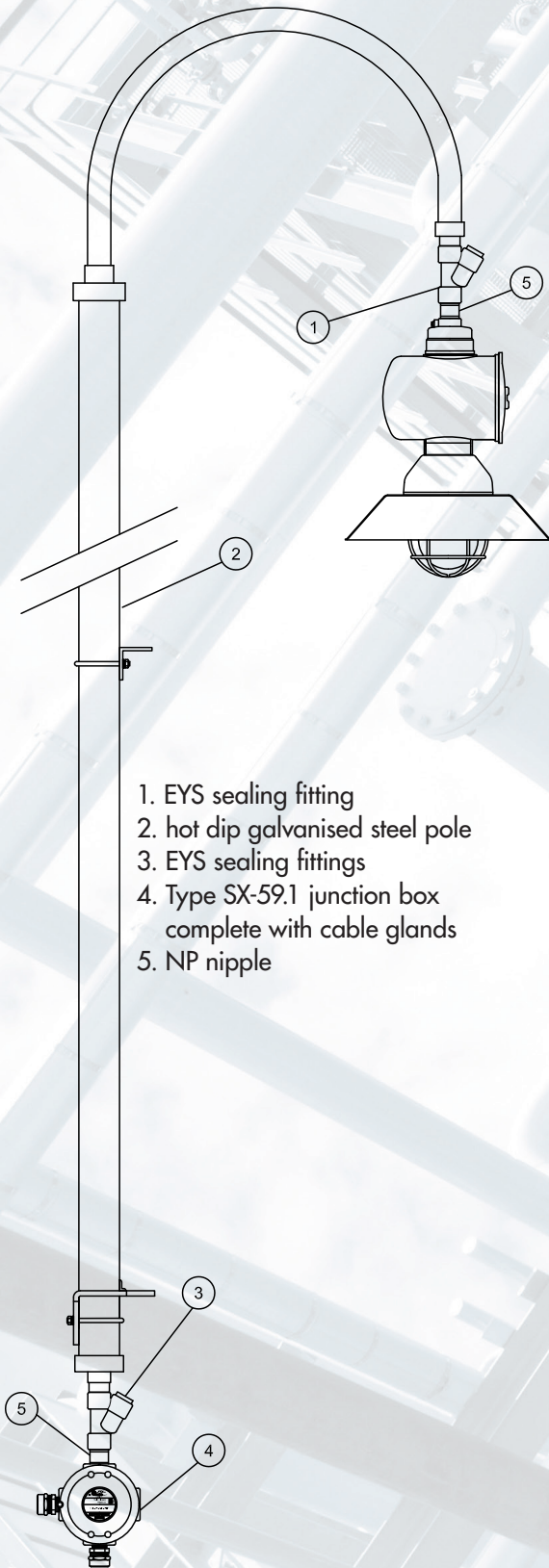

1. EYS sealing fitting
2. hot dip galvanised steel pole
3. EYS sealing fittings
4. Type SX-59.1 junction box complete with cable glands
5. NP nipple

Pole mounting system with bracket

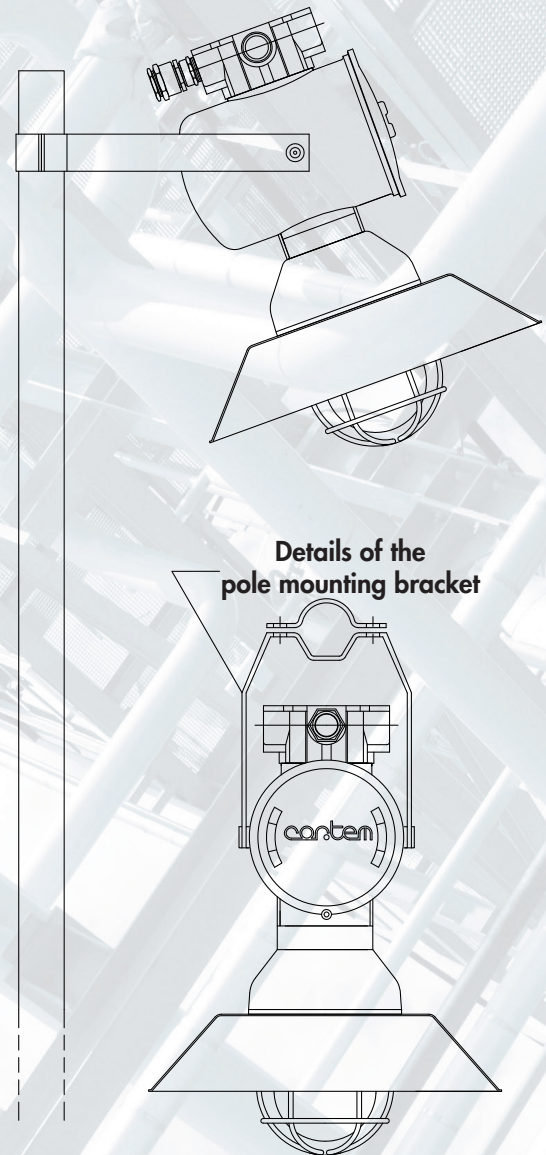

Details of the pole mounting bracket

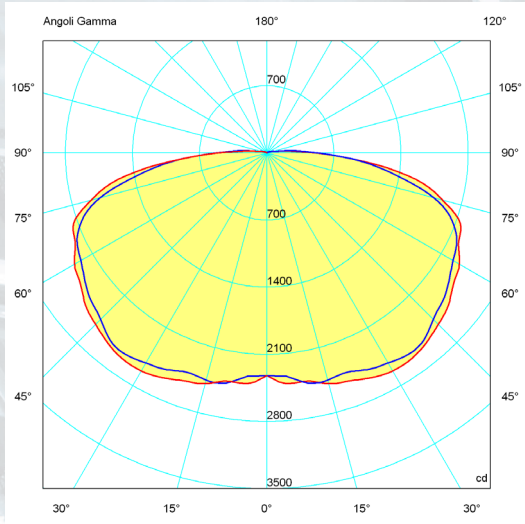

EWA-5080 250W halide

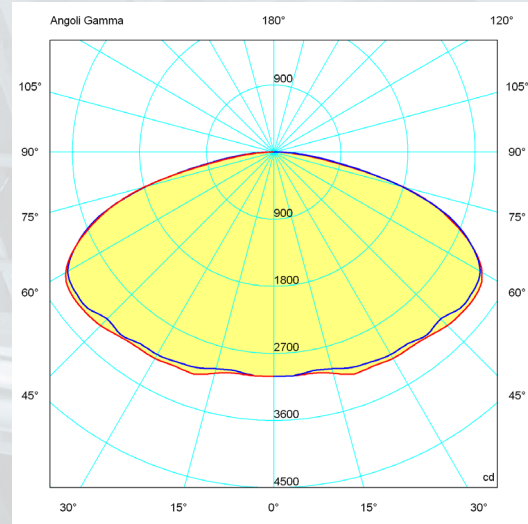

EWA-50100 400W halide

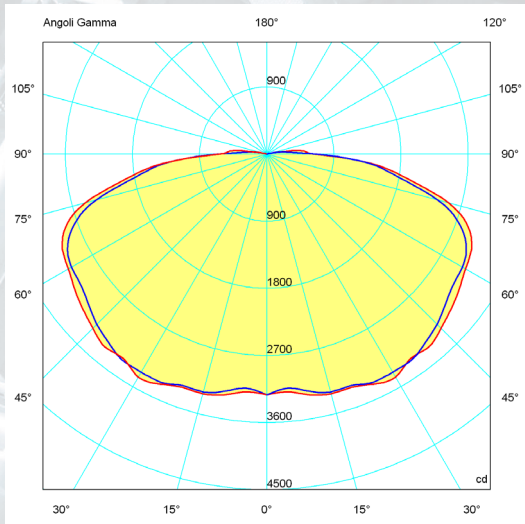

EWA-5080 250W sodium

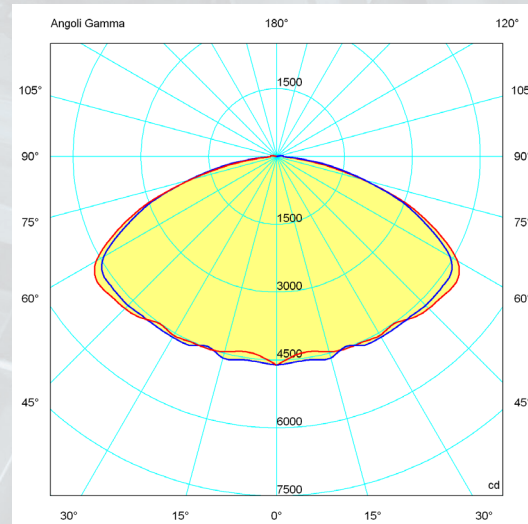

EWA-50100 400W sodium

— = plane 90270
 — = plane 0180