

Design features

High Efficiency and Energy Saving

- Up to 140lm/w lumen efficacy

High-Quality Enclosure Materials

- C5-M rated corrosion
- IK10

Outstanding Optical Performance

- Multiple beam angles with optimal light distribution
- Various color temperature
- Great intensity uniformity to avoid uneven light

Frosted lens option to reduce glare

- Tempered clear glass standard
- Diffused glass lens optional

Strong Water Ingress protection

- IP66 under 5G vibration



Reliable Environmental Adaptability

- Wide temperature range
- Corrosion resistance
- Vibration and impact resistance
- Wind load
- Wet location

Surge protection

- Standard 6kV surge protection; optional 10kV available

Convenient Installation and Maintenance

- Smart bracket mounting size design

Easy-to-Maintain Design



- Replaceable LED module, driver and key components



Why choose HFL LED lighting?

Reliable floodlights. HFL LED luminaires are engineered to deliver high lumen output and maintenance-free long life in the toughest conditions.

HFL 20L vs 400 watt HID

 <p style="margin: 0;">65% REDUCTION IN ENERGY COSTS</p>	 <p style="margin: 0;">77% TOTAL COST OF OWNERSHIP</p>	 <p style="margin: 0;">100% MAINTENANCE REDUCTION</p>
--	--	---

Assumptions: Calculations based on overall life of the LED system. Energy cost of \$.09 per kilowatt; 24 hour per day operation; labor rate of \$75 each for 2 workers; average time for fixture maintenance of 1 hour.

HFL LED floodlights for hazardous areas

HFL LED luminaires

The HFL series is a harsh and hazardous area floodlight for use in Zone 1,2,21 and 22 areas designed to provide up to 40L with outstanding lumen efficacy and easy installation. Compared with traditional HID floodlights, the HFL features high efficacy and long life at high ambient temperatures combined with a robust marine grade housing to reduce the total cost of ownership.

Four versions of the HFL and a variety of optics are available catering for a wide range of applications and a high installed efficacy.



Model	Nominal lumens*	Wattage*	Equivalent HID luminaire	Energy savings
HFL-12L	12556	89W	250W	Up to 64%
HFL-20L	19319	133W	250-400W	Up to 65%
HFL-30L	31541	220W	400-600W	Up to 63%
HFL-40L	37215	260W	600-1000W	Up to 74%

* Tolerance +/- 10%, nominal lumen data for 5700K, clear glass, wide beam angle

Applications

- Locations requiring continuous and consistent light levels in extreme ambient temperatures
- Areas requiring frequent switching of lights
- Where extremely corrosive, wet, dusty, hot and/or cold conditions exist
- Oil and gas refineries, drilling rigs, petrochemical facilities, food and beverage facilities, platforms, loading docks, tunnels, outdoor wall and stanchion mounted general area lighting, and where flammable vapors, gases, ignitable dusts, fibers or flyings are present.

Certification and compliance

- Marking accd.to IECEx:
Ex db eb mb IIC T4...T3 Gb
Ex eb mb IIC T4...T3 Gb
Ex tb IIIC T80°C/ T85°C Db
- Marking accd.to 2014/34/EU:
II 2 G Ex db eb mb IIC T4...T3 Gb,
II 2 G Ex eb mb IIC T4...T3 Gb
II 2 D Ex tb IIIC T80°C/T85°C Db
- Certificate No.
IECEX NEP 24.0045X
SGSNA25ATEX031301X
IECEX NEP 25.0009X

Standard Materials

- Enclosure: copper-free aluminum with C5-M coating
- Lens: tempered and impact resistant glass lens
- Gaskets: silicon
- Guard: standard without guard but SS316L guard is available as option
- Bracket: galvanized steel and SS316L available

Key features

- Instant on and cold temperature operation/no warm-up requirement
- Ambient temperature: -40°C to +55°C
- IP66
- Anti-vibration DNV 2-4
- IK10 enclosure

LED system

- Lumen efficacy up to 140lm/w to save more energy
- 5700K, CRI 70 & 3000K CRI80 as standard (4000K and 5000K optional)
- Type V: 120° wide beam and 30° narrow beam
- Asymmetric Type II option
- Asymmetric Type IV option
- Foggy diffuser with harmful glare protection
- L70: 120,000h@25°C
- L70: 50,000h@55°C

HFL LED floodlights for hazardous areas

Technical data

	HFL 12L	HFL 20L	HFL 30L	HFL 40L
IECEX Certificate of conformity	IECEX NEP 24.0045X			
EC-Type Examination Certificate	SGSNA25ATEX031301X			
GB Certificate	GYB25.1457X			
Voltage Range	100-277Vac 50/60Hz, 125-300Vdc			
Wattage @ 230V	89W	133W	220W	260W
Rated current @230V	394mA	605mA	1009mA	1188mA
Efficiency	>140lm/w (5700K clear)			
Temperature range	Standard -40°C to 55°C; -40°C to 65°C version available			
Power factor	≥0.95			
Ingress Protection	IP66			
Impact Protection	IK10 (the enclosure)			
Optics	Wide Beam 120° type V			
	Narrow Beam 30° Type V			
	Asymmetric Type II			
	Asymmetric Type IV			
CCT	Standard: 5700K & 3000K; 4000K and 5000K are available			
CRI	Cool white>70 and warm white >80			
Surge protection	Standard 6kv; 10kv is as optional			
Material	Enclosure: copper free aluminum (coating); Glass: tempered glass			
Enclosure color	RAL 7035			
Weight	12L 10kg; 20L 12kg; 30L 19kg, 40L 21kg			
Entry size	2xM20 or 2xM25			
Terminal block	6 poles standard (L, L1, L2, L3, N, PE / up to 6 mm ² / others on request)			
DALI	DALI 2 available as option			
Warranty	5 years			

*+/- 10% tolerance

*Detail please refer to certificate and instruction manual

Type key for HFL floodlight series

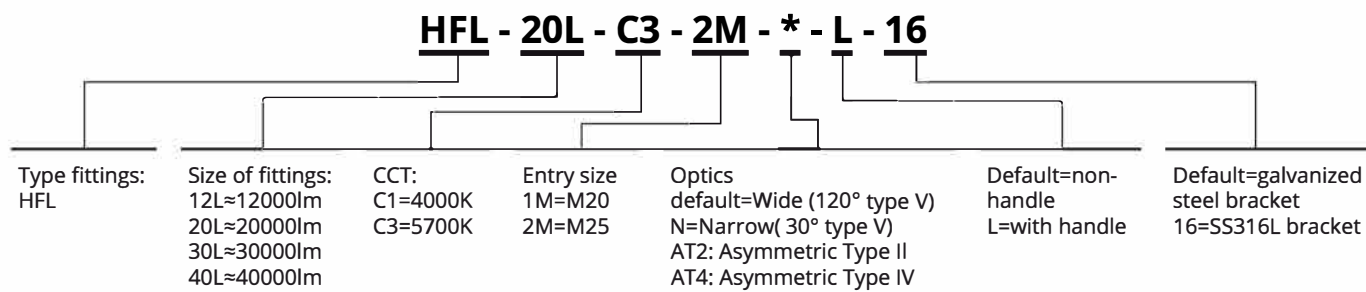

Ordering information

Order code	Product Type	Color temperature	Optics	Terminals	Entry Threaded	Ex e Threaded Plug
CCL2006778S	HFL-12L-C3-2M-16	5700K	120° wide beam Type V	1x6	2x M25	1
CCL2006810S	HFL-20L-C3-2M-16	5700K	120° wide beam Type V	1x6	2x M25	1
CCL2006842S	HFL-30L-C3-2M-16	5700K	120° wide beam Type V	1x6	2x M25	1
CCL2006874S	HFL-40L-C3-2M-16	5700K	120° wide beam Type V	1x6	2x M25	1

*Standard version without cable gland. If need, please order separately

*Contact your local sales representatives for special requirements.

HFL LED floodlights for hazardous areas

Dimension

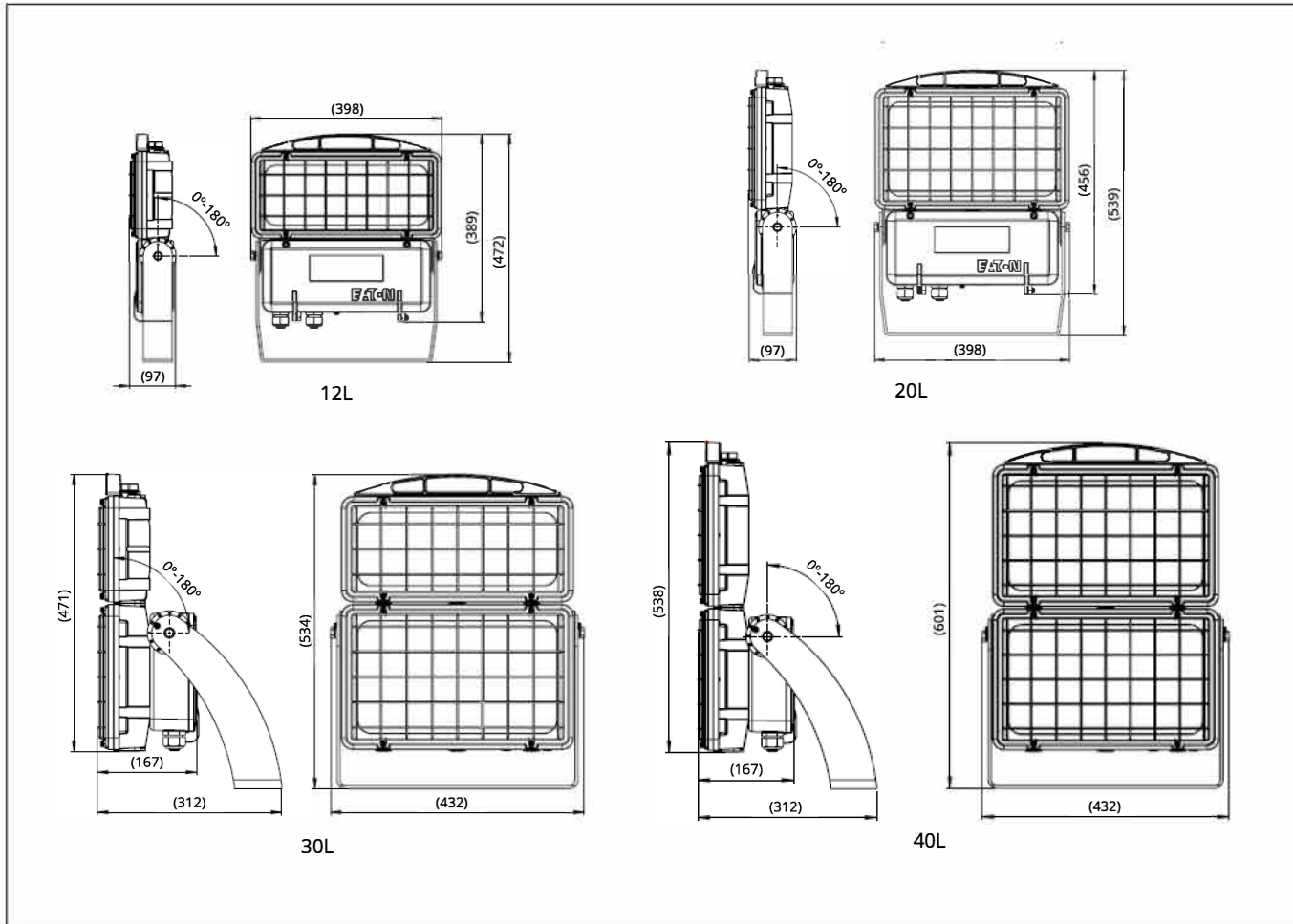

* Standard version comes without guard, please select if needed.

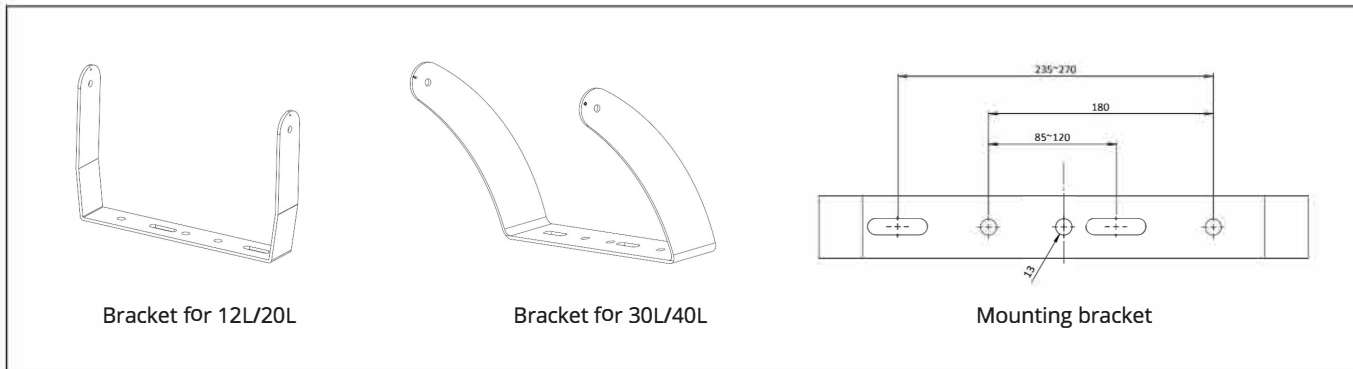

HFL LED floodlights for hazardous areas

Accessory can be ordered

Order material number	Description
CHR7005	Safety Chain with eyebolt

Metallic Cable Glands (Order Separately)

ADE-1F2

Catalog #	Metric Thread Size	Cable Types	Cable sealing range - Min	Cable sealing range - Max
ADE1M251NPN	M25	Non-armoured,	7	12
ADE1M252NPN	M25	Marine shipboard, Type P, Tray cable (armoured)	10	15.5
ADE1M253NPN	M25		13.5	20.5



ADE-4F

Catalog #	Metric Thread Size	Cable Types	Cable sealing range inner sheath		Cable sealing range outer sheath		Armor	
			Min.	Max.	Min.	Max.	Min.	Max.
ADE4M251NPN	M25	SWA, SWB, STA, Braided marine shipboard,	7	12	10	16	0.2	1.3
ADE4M252NPN	M25	Type P; Leadsheathed cable (with addition of earthing washer)	10	15.5	13.5	21	0.2	1.3
ADE4M253NPN	M25		13.5	20.5	18	27.5	0.2	1.6



ADE-1F2 and ADE-4F catalog numbers are for nickel-plated brass; For other material options, please contact our sales representative.

Polar curve

