



SLED series LED floodlights

SLED series floodlights with LED technology combine lightweight, compact design, high performance in terms of reliability, safety, efficiency and energy saving. The SLED-250, 400 and 600 models are characterized by LEDs with optics “square shaped beam” that permits a light distribution and a perfectly uniform lighting in every direction. This photometry makes them particularly suitable for installation in the perimeter areas or wall in all those areas defined as dangerous for the presence of gas, explosive dust, such as Zone 1, 2, 21, 22. On the other hand, the SLED 401, 601, 1000 and 1001 have no reflector optics and are characterized by a diffused light beam and greater Lumen Output. The finned body of the floodlight acts as a heat sink for the LED plate, allowing the installation of greater light output without incurring the deterioration of the LEDs. The flat protective glass is resistant to shocks and high temperatures and ensures an environment friendly lighting. Due to their high luminous output and to a white light with a colour rendering index greater than 70, SLED series floodlights are able to replace the traditional rectangular floodlights that use discharge lamps sodium vapour or metal halide, guaranteeing lighting quality and visual comfort.

Application sectors:



CERTIFICATION DATA

Classification:	Group II	Category 2GD		
Installation: EN 60079.14	zone 1 - zone 2 (Gas)	zone 21 - zone 22 (Dust)		
Marking:	CE 0722 Ex II 2GD Ex de IIB+H2 T5/T6 Gb - Ex tb IIIC T100°C T85°C Db IP66			
Certification:	ATEX CML 19 ATEX 1312			
	IECEX IECEX CML 17.0004	All IEC Ex, TR CU and INMETRO certification data contact comm@antideflagrante.com		
	TR CU AVAILABLE For SLED-250, SLED-400, SLED-600			
	INMETRO DNV 19.0034 X For SLED-250, SLED-400, SLED-600, SLED-1000			
Standards:	CENELEC EN 60079-0: 2012, EN 60079-7: 2007, EN 60079-18: 2009, EN 60079-31: 2014 and EUROPEAN DIRECTIVE 2014/34/UE IEC 60079-0: 2011, IEC 60079-1: 2014-06, IEC 60079-28: 2015, IEC 60079-31: 2013, IEC 60079-7: 2015 European Directive 2006/95 Low voltage European Directive 2004/108 Electromagnetic compatibility European Directive 2003/108 WEEE Waste electrical and electronic equipment European Directive 2011/64 RoHS			
Degree of protection:	IP66			

Ambient temperature, Class. temperature, Max. surface temp:

Code	(IIB+H ₂)		(for IIB only)	
SLED-250	-20°C +40°C T6/85°C	-20°C +60°C T5/100°C	-40°C +40°C T6/85°C	-40°C +60°C T5/100°C
SLED-400	-20°C +40°C T6/85°C	-20°C +60°C T5/100°C	-40°C +40°C T6/85°C	-40°C +60°C T5/100°C
SLED-600	-20°C +40°C T6/85°C	-20°C +60°C T5/100°C	-40°C +40°C T6/85°C	-40°C +60°C T5/100°C
SLED-401	-20°C +40°C T5/98°C	-	-40°C +40°C T5/99°C	-
SLED-601	-20°C +40°C T5/90°C	-20°C +50°C T5/100°C	-40°C +40°C T5/90°C	-40°C +50°C T5/100°C
SLED-1000	-20°C +40°C T5/93°C	-20°C +50°C T4/103°C	-40°C +40°C T5/93°C	-40°C +50°C T4/103°C
SLED-1001	-20°C +40°C T6/85°C	-20°C +55°C T5/100°C	-40°C +40°C T6/85°C	-40°C +55°C T5/100°C

SLED series LED floodlights



EXEMPT FROM
PHOTOBIOLOGICAL RISK
(STANDARD IEC / EN 62471)

ORIGINAL PRODUCT

MECHANICAL FEATURES

- Body:** Low copper content aluminium alloy fitted with cooling fins for better heat dissipation
- Glass face:** Shock and temperature resistant tempered glass sealed with aluminium ring Galvanised
- Supporting bracket:** steel
- Gaskets:** Acid, hydrocarbon and high temperature resistant silicone
- Bolts and screws:** Stainless steel
- Entries:** 2 x ISO M20 entries (SLED-250, SLED-401);
(Floodlight kit with plug PLG11B and cable gland)
ISO M25 entries (SLED-400, SLED-600, SLED-401, SLED-1000, SLED-1001)
(Floodlight kit with plug PLG21B and cable gland)
- Coating:** Polyester coating Ral 7035 (Light grey)

Corrosion Resistance: The STANDARD of the aluminium alloy used by manufacturer has passed the tests required by standards EN60068-2-30 (hot/humid cycles) and EN60068-2-11 (salt mist tests)

ACCESSORIES AVAILABLE / SPECIAL REQUESTS

Different colour temperature (code SLED-250/**2700K**)



SLED series LED floodlights

Code	Dimensions mm				Watt	Class / Max surface temp. °C				Weight kg	 mm
	A	B	B1	C		TA=+40°C	TA=+50°C	TA=+55°C	TA=+60°C		
SLED-250	310	360	460	135	122 W	T6/85°C	-	-	T5/100°C	13,5	470x345x150
SLED-400	360	444	520	145	194 W	T6/85°C	-	-	T5/100°C	20,3	540x410x180
SLED-600	440	540	600	165	290 W	T6/85°C	-	-	T5/100°C	32,4	600x465x180
SLED-401	310	360	460	135	180 W	T5/98°C	-	-	-	13,5	470x345x150
SLED-601	360	444	520	145	290 W	T5/90°C	T5/100°C	-	-	20,3	540x410x180
SLED-1000	440	540	600	165	400 W	T5/93°C	T4/103°C	-	-	32,4	600x465x180
SLED-1001	440	540	600	165	500 W	T6/85°C	T5/95°C	T5/T100°C	-		600x465x180

DIMENSIONAL DRAWING

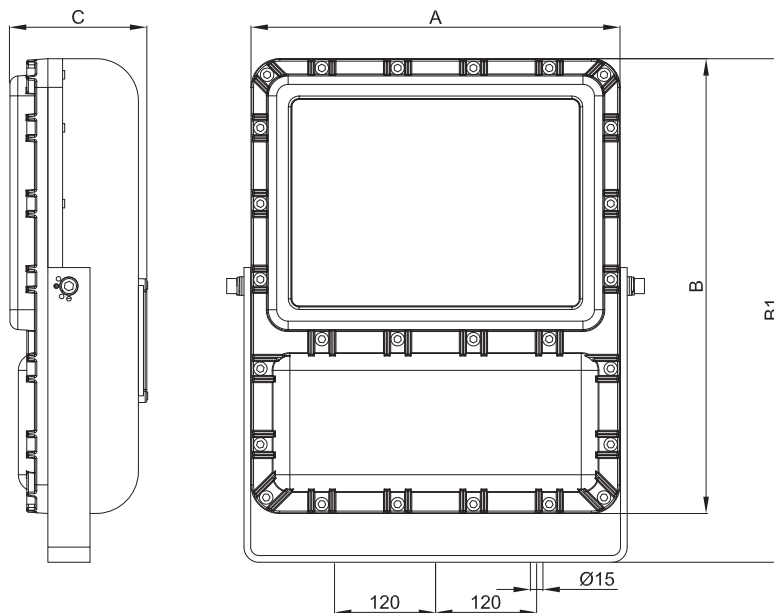

Dimensions in mm

EXPLODED DIAGRAM OF SLED-600 FLOODLIGHT

Descriptions:

1. Body including optics and LED board
2. Cover with tempered glass
3. UNI5931 stainless steel screws
4. 'Ex e' housing complete with power supply and terminals
5. Mounting bracket
6. 'Ex e' housing complete with terminals L, N, PE, Section max. 4 mm², suitable for loop-in, loop-out
7. Cover equipped with captive screws
8. Reflector optics

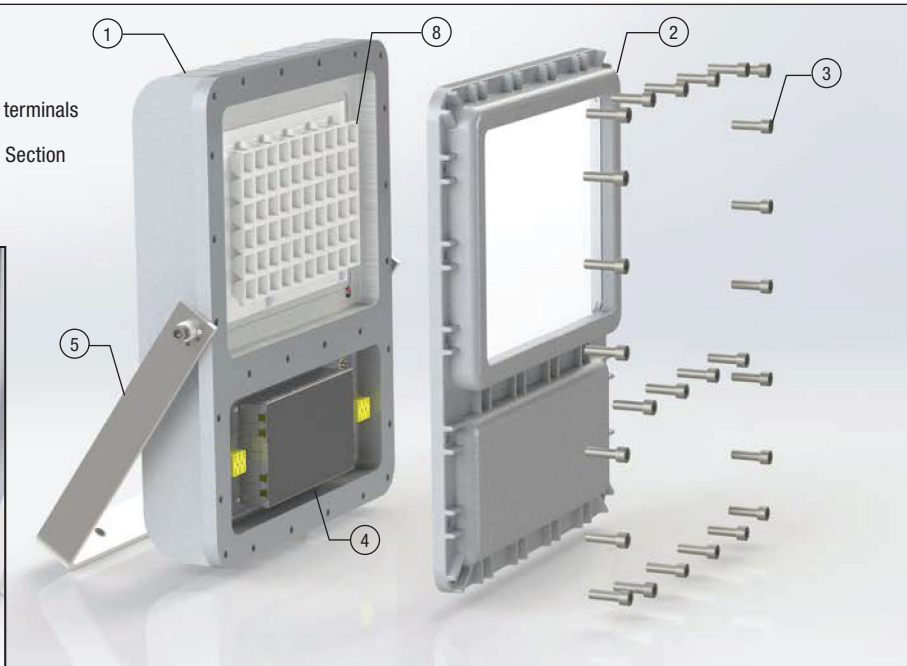
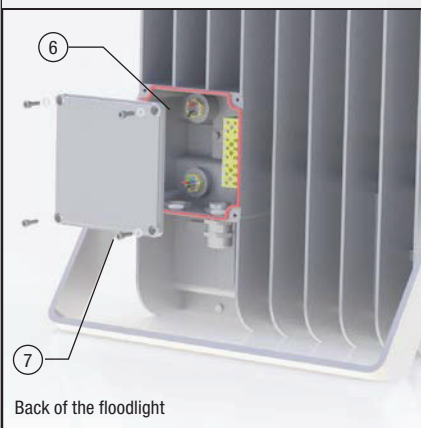

SLED series LED floodlights "square shaped beam"



Electrical features	SLED-250	SLED-400	SLED-600
Power supply:	100-277 Vac \pm 10%	120-277 Vac \pm 10%	120-277 Vac \pm 10%
Rated frequency:	50-60 Hz \pm 5%	50-60 Hz \pm 5%	50-60 Hz \pm 5%
Power consumption*:	122 W	194 W	290 W
Connection:	Direct connection to terminal board L, N, Pe. Section 4mm ² , suitable for loop-in/loop-out		
Power factor*:	>0,95	>0,96	>0,97
Rated current*:	559 mA	877 mA	1303 mA
EMC (electromagnetic compatibility):	EN 55015, EN 61547, IEC 61000-3-2, IEC 61000-3-3, IEC 61000-4...		
THD (total harmonic distortion):	<15% 100-277 Vac	<20% 120-277 Vac	<20% 120-277 Vac
Over-voltage protection:	2 kV	4 kV	4 kV
Driver performances:	Over-Voltage protection, Over-Current protection, Short-Circuit protection		
Dimmer (on request):	(0-10 V) o PWM	(0-10 V)	(0-10 V)
Photometric features			
Viewing angle:	60°	60°	60°
LED:	Cree	Cree	Cree
Type:	Cool White	Cool White	Cool White
Colour temperature:	~ 6500 K	~ 6500 K	~ 6500 K
CRI**:	>70	>70	>70
Instant Restrike:	YES	YES	YES
L80:	> 72600 h	> 72600 h	> 72600 h
Lumen:	12387 lm	20744 lm	30799 lm
Maximum light intensity:	5206 cd	23491 cd	33976 cd
Overall efficiency:	101 lm/W	107 lm/W	106,2 lm/W

* Test at 230Vac

** Different CRI on request

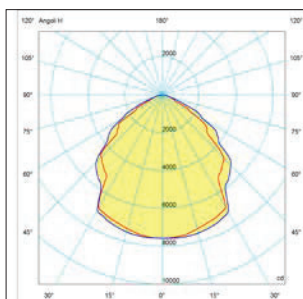

SLED-250 Luminous flux:
12387 lm

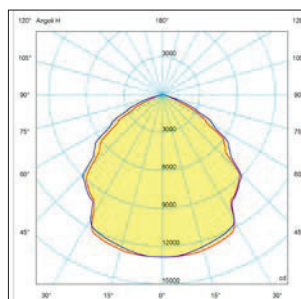

SLED-400 Luminous flux:
20744 lm

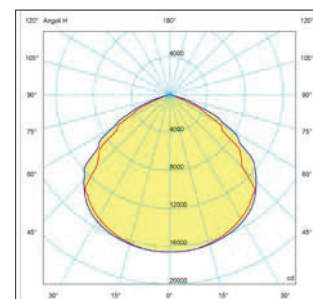

SLED-600 Luminous flux:
30799 lm

— = plane 90270
— = plane 0180



SLED series LED floodlights

Electrical features	SLED-401	SLED-601	SLED-1000	SLED-1001 <small>NEW</small>
Power supply:	120-277 Vac ±10%	120-277 Vac ±10%	120-277 Vac ±10%	100-240 Vac ±10%
Rated frequency:	50-60 Hz ±5%	50-60 Hz ±5%	50-60 Hz ±5%	50-60 Hz ±5%
Power consumption*:	180 W	290 W	400 W	500 W
Connection:	Direct connection to terminal board L, N, Pe. Section 4mm ² , suitable for loop-in/loop-out			
Power factor*:	>0,98	>0,98	>0,97	>0,96
Rated current*:	798 mA	1281 mA	1793 mA	2277 mA
EMC (electromagnetic compatibility):	EN 55015, EN 61547, IEC 61000-3-2, IEC 61000-3-3, IEC 61000-4-...			
THD (total harmonic distortion):	<10% 220-240 Vac	<10% 220-240 Vac	<20% 120-277 Vac	<10% 220-240 Vac
Over-voltage protection:	6-10 kV	6-10 kV	2-4 kV	6-10 kV
Driver performances:	Over-Voltage protection, Over-Current protection, Short-Circuit protection			
Dimmer (on request):	(0-10 V) o PWM	(0-10 V) / PWM	(0-10 V) / PWM	(0-10 V) / PWM
Photometric features				
Viewing angle:	98°	100°	105°	110°
LED:	Cree	Cree	Cree	Cree
Type:	Cool White	Cool White	Cool White	Cool White
Colour temperature:	~ 5700 K	~ 5700 K	~ 5700 K	~ 5000 K
CRI**:	>70	>70	>70	>70
Instant Restrike:	YES	YES	YES	YES
L80*:	> 72600 h	> 72600 h	> 72600 h	> 118000
Lumen:	18490 lm	32092 lm	46145 lm	58045 lm
Maximum light intensity:	7600 cd	12899 cd	16600 cd	22360 cd
Overall efficiency:	102 lm/W	110 lm/W	115 lm/W	117 lm/W

* Test at 230Vac

** Different CRI on request

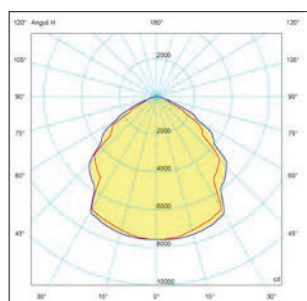

SLED-401 Luminous flux:
18490 lm

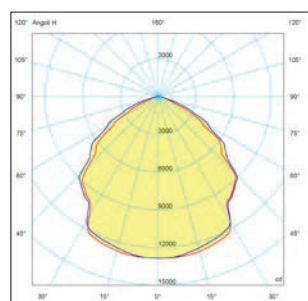

SLED-601 Luminous flux:
32092 lm

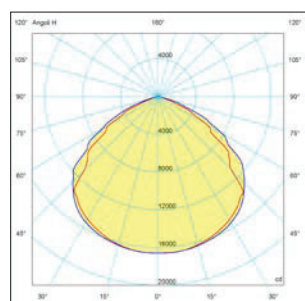

SLED-1000 Luminous flux:
46145 lm

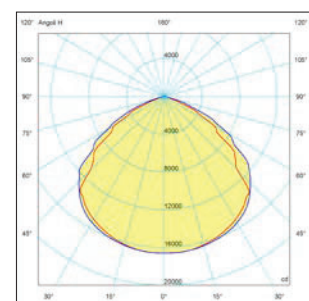

SLED-1001 Luminous flux:
58045 lm

— = plane 90270
— = plane 0180

SLED series Accessories and spare parts available on request

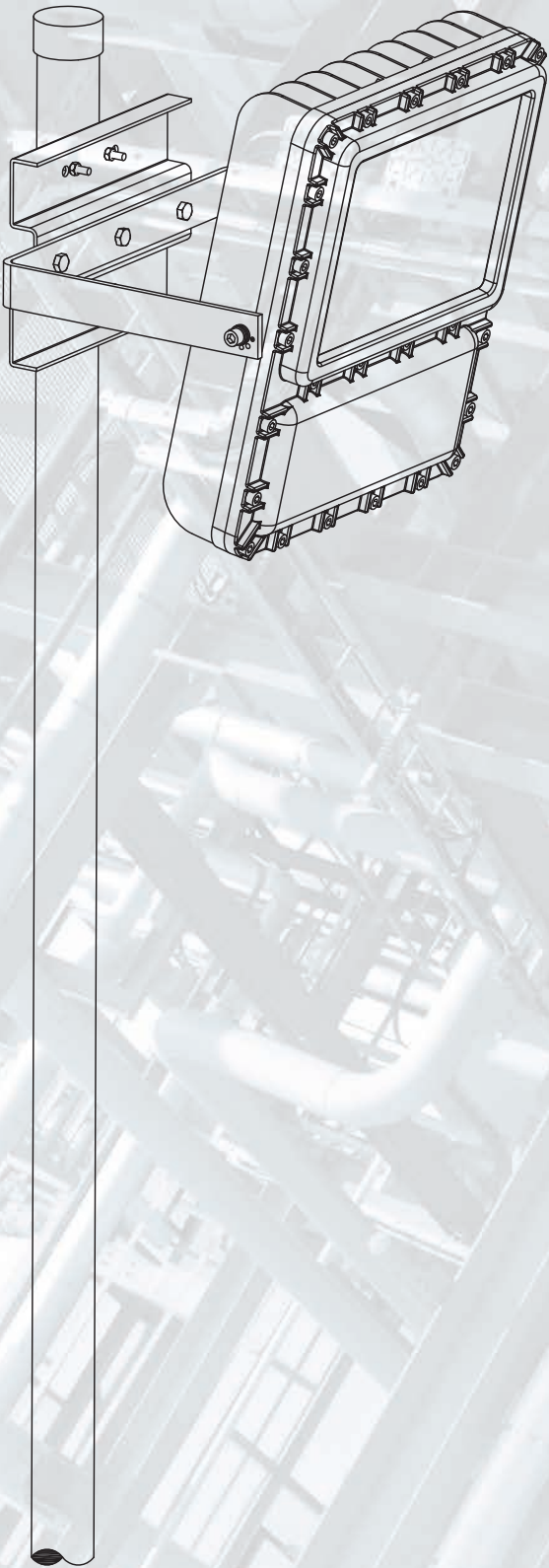

ILLUSTRATION	DESCRIPTION	MODEL	FEATURES	CODE	KEY
	Reinforced supporting bracket for mounting on movement facilities	SLED-600 SLED-1000 SLED-1001	Material: galvanised steel	G-558/1	
	Frame for pole mounting	Per tutti i modelli	Material: galvanised steel	G-0534	
	Swivel base for 360° adjustment	SLED-400 SLED-601 SLED-600 SLED-1000 SLED-1001	Material: aluminum RAL 7035 painted	G-326 + G-327	
	Cable gland for nonarmored cables	SLED-250 SLED-401	std. range cable 6,3÷11,6		
		SLED-400 SLED-601 SLED-600 SLED-1000 SLED-1001	std. range cable 11÷20		
	Front ring with glass	SLED-250 SLED-401	Low copper content aluminium alloy with tempered glass	G250-0622	
		SLED-400 SLED-601		G400-0622	
		SLED-600 SLED-1000 SLED-1001		G-0622	
	Supporting bracket	SLED-250 SLED-401	Material: galvanised steel	G-901	
		SLED-400 SLED-601		G-896	
		SLED-600 SLED-1000 SLED-1001		G-558	
	Optics	SLED-250 SLED-400 SLED-600	Material: polycarbonate	PIXEL12	
	Power supply	SLED-250	100-277 Vac	LEDDEV100	
		SLED-400	120-277 Vac	LEDDSLED600	
		SLED-600	120-277 Vac	LEDDSLED600	
		SLED-401	120-277 Vac	LEDDSLED401	
		SLED-601	120-277 Vac	LEDDSLED601	
		SLED-1000	120-277 Vac	LEDDEV100 (x2)	
		SLED-1001	100-277 Vac	LEDDSLED1001	



Installation and mounting methods SLED series

Example of pole mounting



Example of vertical mounting on structure

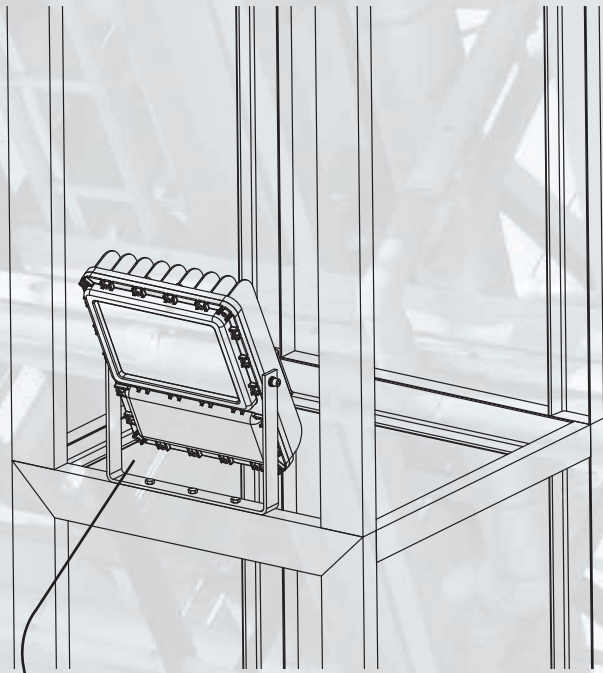

Angle of rotation of 360 °

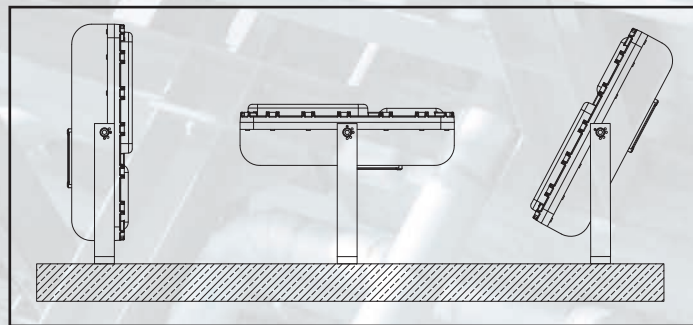

Example of horizontal mounting on structure

